

# AS1341

## Evaluation Board Application Note

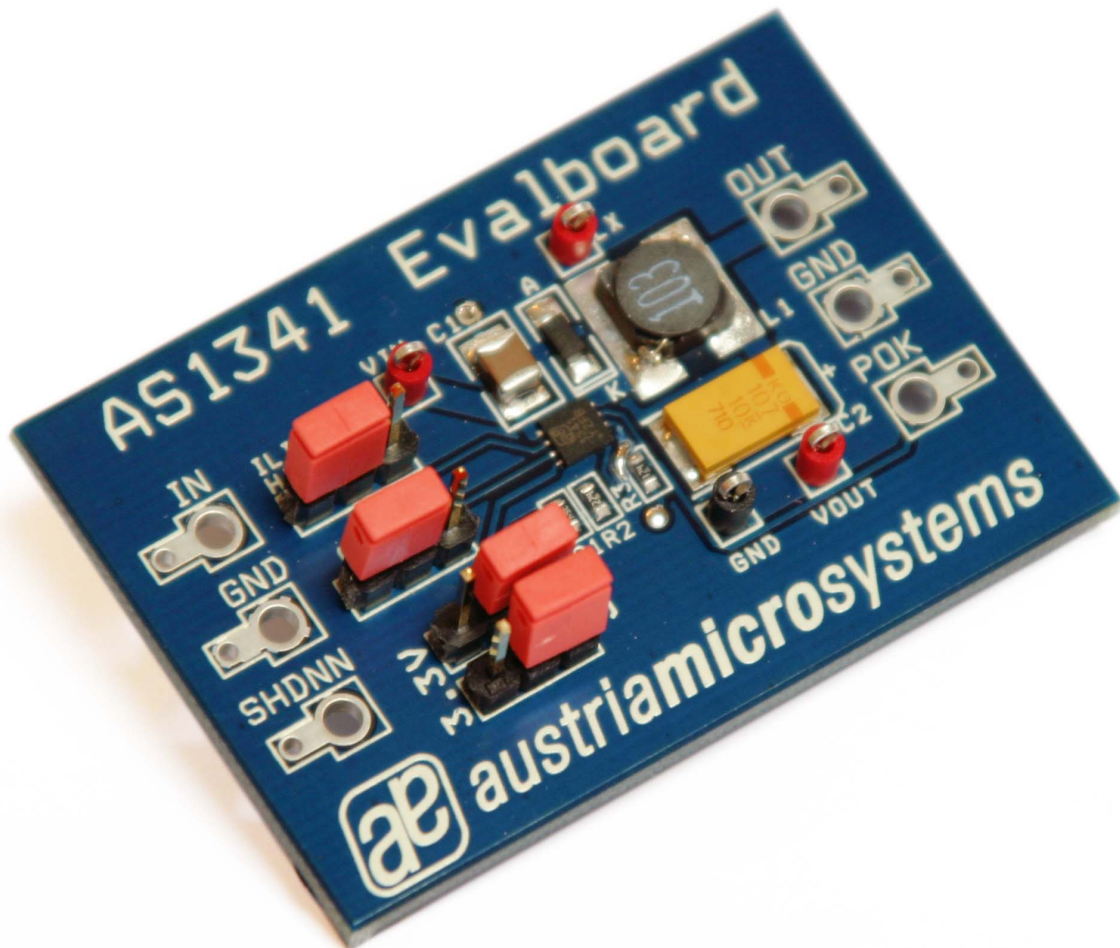

## General Description

### Board Description

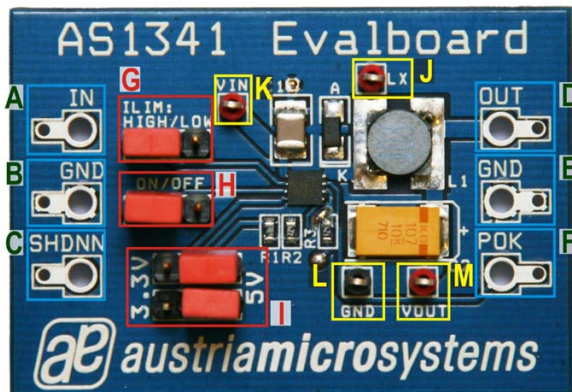

Figure 1: Board Description

### Connector Description

Label	Name	Description	Info
A	<b>VIN</b>	Input Voltage	Input voltage ranging from 4.5V to 20V
B	<b>GND</b>	Ground	
C	<b>SHDNN</b>	Enable Jumper	
D	<b>OUT</b>	Power Output Connector	
E	<b>GND</b>	Ground	
F	<b>POK</b>	Power-OK Signal	

### Jumper Description

Label	Name	Description	Info
G	<b>ILIM: HIGH/LOW</b>	Current Limiter	<input type="checkbox"/> LOW ILIMIT: 0.7A <input type="checkbox"/> HIGH ILIMIT: 1.4A
H	<b>ON/OFF</b>	Enable Jumper	<input type="checkbox"/> ON <input type="checkbox"/> OFF
I	<b>3.3V 5V</b>		<input type="checkbox"/> 3.3V <input type="checkbox"/> 5V

### Measurement Points Description

Label	Name	Description	Info
J	<b>LX</b>	External Conductor	
K	<b>GND</b>	Power Supply Connectors for	
L	<b>VIN</b>	VBATT and Ground.	
M	<b>OUT</b>	Power Output Connector	

## Operational sequence

This evaluation board comes with the AS1341.

1. If not present get the [datasheet](#) for the [AS1341](#) from [www.austriamicrosystems.com](http://www.austriamicrosystems.com). Drive the IC on the Demoboard only with the recommended settings and values as described in the datasheet.
2. Connect a 4.5V to 20V power supply (VIN “A” and GND “B”).
3. Perform measurements at the measurement points “J” to “M”.

If there are questions do not hesitate to contact us. See contact information at the end of the application note.

## Optional Features

### Setting the output voltage

The AS1341 has a default output voltage of 5V if FB is set to GND. Additionally the output voltage can be set between 1.25 and VIN via an additionally resistor R1 & R2. The required resistor value for a certain output voltage can be calculated as shown in equation 1.

$$R1=R2*(V_{OUT}/V_{FB}-1) \text{ (Eq1)}$$

R1 = 360kΩ  
R2 = 220kΩ  
VFB = 1.25V

Predefined resistor values on board are set for 3.3V. If another voltage is required R1 and R2 can be replaced and Jumpers “I” must be set to 3.3V.

### Using the current limiter

The current limit can be set via jumper ILIM “G” between 700mA & 1.4A. This connects the pin ILIMIT of the AS1341 either to GND or to VCC

## Layout of evaluation board

### Board schematics and layout

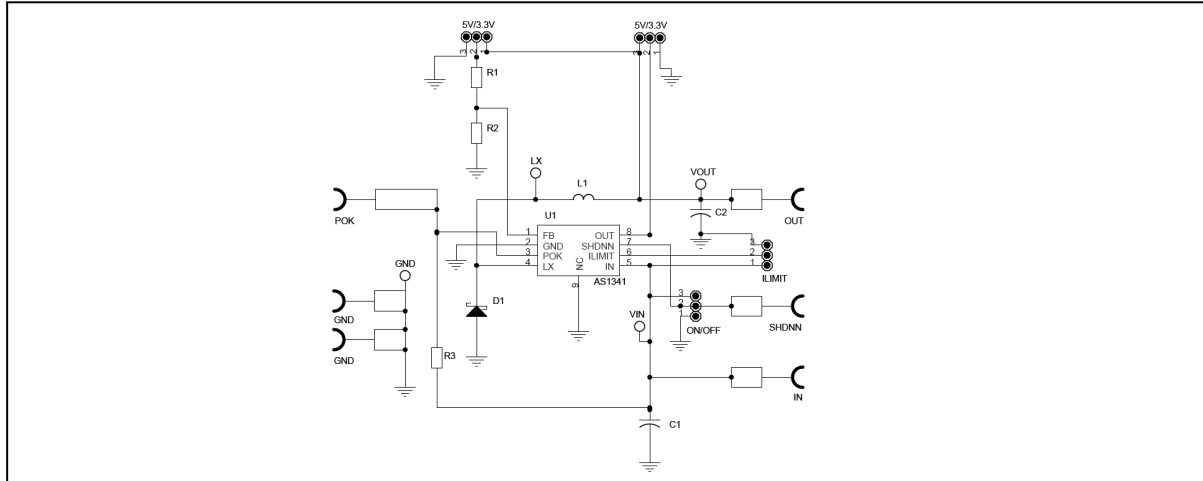

Figure 3: Schematics

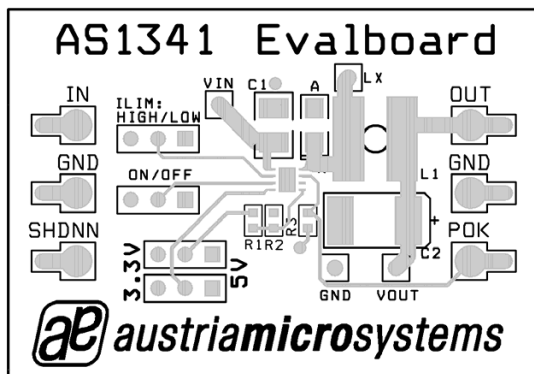

Figure 4: Top view

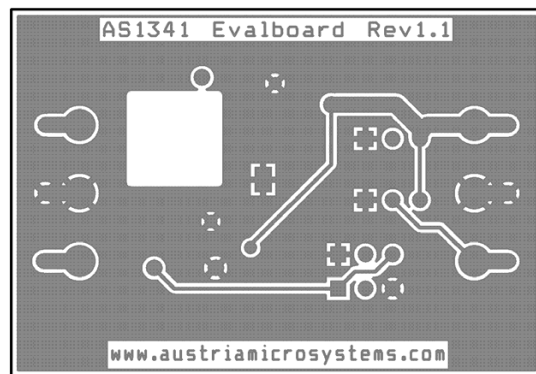

Figure 5: Bottom view

### Assembly List

Label	Info	Type	Manufacturer
C1	10 $\mu$ F, 25V, X7R	GRM32DR71E106KA12L	Murata
C2	100 $\mu$ F, 10V	T520V107M010ATE018	Kemet
L1	10 $\mu$ H, 85m $\Omega$ , 1.6A	MSS6132-103	Coilcraft
R1	360k $\Omega$		
R2	220k $\Omega$		
R3	120 $\Omega$		
D1	Shottky Diode	MBR120VL	

## Copyright

Copyright © 1997-2008, austriamicrosystems AG, Schloss Premstaetten, 8141 Unterpremstaetten, Austria-Europe. Trademarks Registered ®. All rights reserved. The material herein may not be reproduced, adapted, merged, translated, stored, or used without the prior written consent of the copyright owner.

All products and companies mentioned are trademarks or registered trademarks of their respective companies.

## Disclaimer

Devices sold by austriamicrosystems AG are covered by the warranty and patent indemnification provisions appearing in its Term of Sale. austriamicrosystems AG makes no warranty, express, statutory, implied, or by description regarding the information set forth herein or regarding the freedom of the described devices from patent infringement. Austriamicrosystems AG reserves the right to change specifications and prices at any time and without notice. Therefore, prior to designing this product into a system, it is necessary to check with austriamicrosystems AG for current information.

This product is intended for use in normal commercial applications. Applications requiring extended temperature range, unusual environmental requirements, or high reliability applications, such as military, medical life-support or lifesustaining equipment are specifically not recommended without additional processing by austriamicrosystems AG for each application. For shipments of less than 100 parts the manufacturing flow might show deviations from the standard production flow, such as test flow or test location.

The information furnished here by austriamicrosystems AG is believed to be correct and accurate. However, austriamicrosystems AG shall not be liable to recipient or any third party for any damages, including but not limited to personal injury, property damage, loss of profits, loss of use, interruption of business or indirect, special, incidental or consequential damages, of any kind, in connection with or arising out of the furnishing, performance or use of the technical data herein. No obligation or liability to recipient or any third party shall arise or flow out of austriamicrosystems AG rendering of technical or other services.



## Contact Information

### Headquarters

austriamicrosystems AG  
A-8141 Schloss Premstätten, Austria  
T. +43 (0) 3136 500 0  
F. +43 (0) 3136 5692

For Sales Offices, Distributors and Representatives, please visit:  
<http://www.austriamicrosystems.com/contact>