

# AS3654

## Power Management Unit with 18 Bit Audio DAC + Headphone Amplifier, DCDC Charger, 3 Buck DCDCs, 3 Boost DCDCs, 5 LDOs, Current Sinks, ADC

### 1 General Description

The AS3654 is a highly integrated solution for power supply generation and monitoring, battery management including charging. It is controlled via a serial control interface and integrates all necessary system specific functions such as clock, reset and interrupt generation, voltage and temperature monitoring.

### 2 Key Features

- System Control
  - Serial Control Interface
  - On/Off Control Module
  - Reset Generation for system controller
  - Programmable Interrupt Controller
  - Watchdog
  - Low power off mode (9 $\mu$ A; 2.5V LDO on)
- Supply Voltage Generation
  - 1 RF Programmable Low Noise LDOs (400mA)
  - 1 RF Programmable Low Noise LDOs (150mA) 2 RF Programmable Low Noise LDOs (150mA)
  - 2 Programmable Digital Low Power LDOs (200mA)
  - 2 General Purpose PWM DC/DC step up converter with two programmable current sinks (e.g. for white led)
  - 3 General Purpose high efficiency DC/DC step down converter
  - 1 Low noise charge pump with 5V output voltage
  - 1 Ultra Low Power 2.5V LDO (always on)
- Current sinks
  - 4 programmable(6-bit) from 0.625 to 40mA optional useable as GPIOs
  - 3 programmable high voltage (15V) (6-bit) from 0.625 to 40mA
  - internal PWM generator
- 10-bit Successive Approximation ADC
  - 40 $\mu$ s conversation time
- Battery Management
  - Full featured chemistry independent step down charger with included Gas Gauge and Current limitation
  - 0.2  $\Omega$  Battery switch for start-up during trickle charging
  - Integrated USB charger up to 400mA
- Power Management Features
  - Wide Battery Supply Range 3.0...5.5V
  - On-Chip Bandgap Tuning for High Accuracy ( $\pm$ 1%)
  - Current protection
  - Thermal Protection with internal temperature sensor
- Audio
  - 18 Bit Audio DAC
  - Two Digital Audio Inputs (I2S interface)
  - 2.9V low Noise LDO for Audio DAC
  - Headphone Amplifier Output with GND separation
  - GND Buffer for Headphone Amplifier
  - Line/ Headphone output with GND separation
- Programmable System clock
  - 1.6 MHz to 2.3 MHz with 100 kHz steps
- Package
  - BGA100 9x9mm, 0.8mm pitch

### 3 Application

- Power Management Unit
- 1 Cell Li+ or 3 Cell NiMH powered devices
- Car battery powered systems with and without internal battery

## 4 Block Diagram

Figure 1 – AS3654 Block Diagram

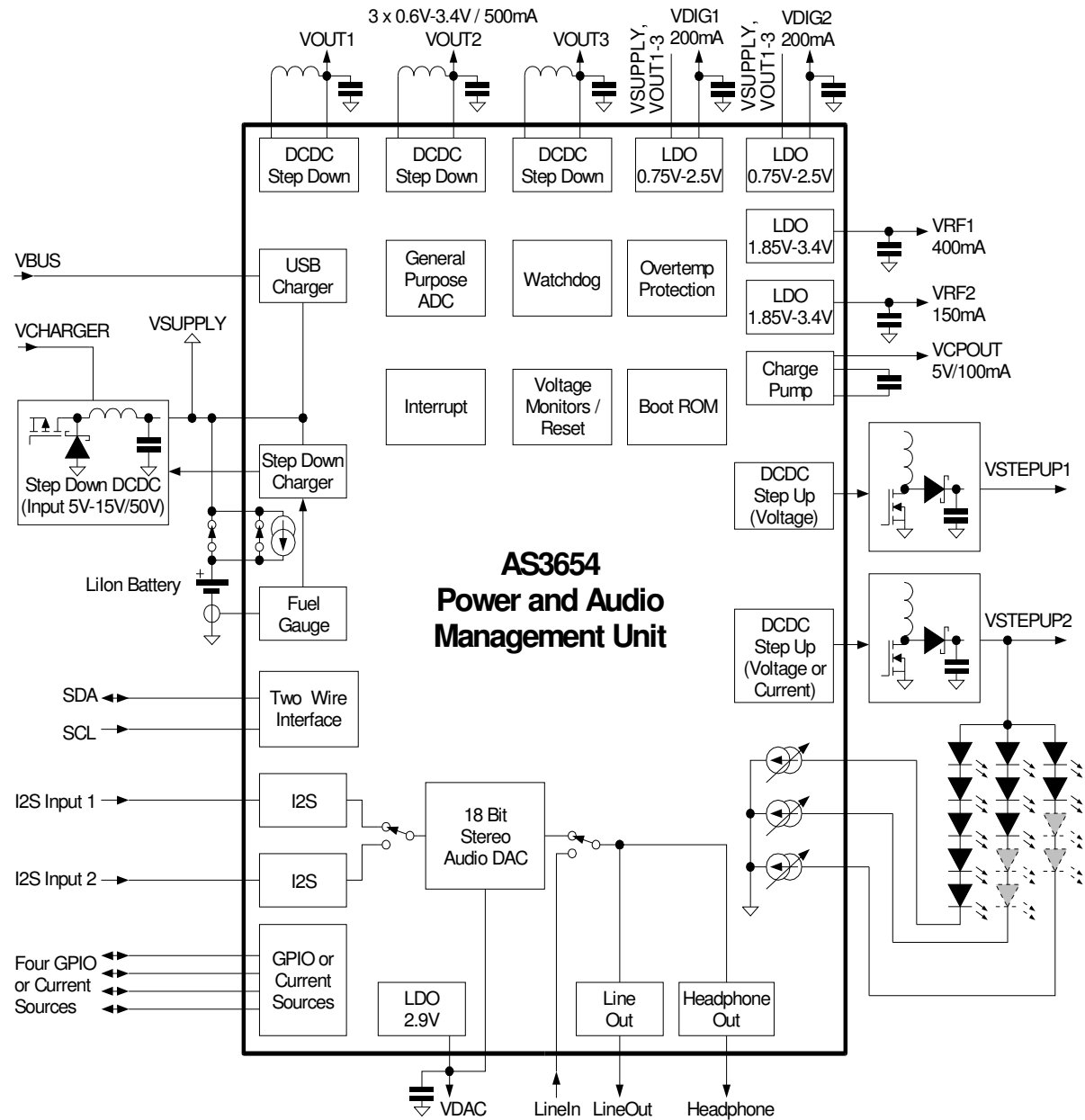

## Copyright

Copyright © 1997-2006, austriamicrosystems AG, Schloss Premstaetten, 8141 Unterpremstaetten, Austria-Europe. Trademarks Registered ®. All rights reserved. The material herein may not be reproduced, adapted, merged, translated, stored, or used without the prior written consent of the copyright owner.

All products and companies mentioned are trademarks of their respective companies.

## Disclaimer

Devices sold by austriamicrosystems AG are covered by the warranty and patent identification provisions appearing in its Term of Sale. austriamicrosystems AG makes no warranty, express, statutory, implied, or by description regarding the information set forth herein or regarding the freedom of the described devices from patent infringement. austriamicrosystems AG reserves the right to change specifications and prices at any time and without notice. Therefore, prior to designing this product into a system, it is necessary to check with austriamicrosystems AG for current information. This product is intended for use in normal commercial applications. Applications requiring extended temperature range, unusual environmental requirements, or high reliability applications, such as military, medical life-support or life-sustaining equipment are specifically not recommended without additional processing by austriamicrosystems AG for each application.

The information furnished here by austriamicrosystems AG is believed to be correct and accurate. However, austriamicrosystems AG shall not be liable to recipient or any third party for any damages, including but not limited to personal injury, property damage, loss of profits, loss of use, interruption of business or indirect, special, incidental or consequential damages, of any kind, in connection with or arising out of the furnishing, performance or use of the technical data herein. No obligation or liability to recipient or any third party shall arise or flow out of austriamicrosystems AG rendering of technical or other services.

## Contact Information

Headquarters:

austriamicrosystems AG  
Business Unit Communications  
A 8141 Schloss Premstätten, Austria  
T. +43 (0) 3136 500 0  
F. +43 (0) 3136 5692  
info@austriamicrosystems.com

For Sales Offices, Distributors and Representatives, please visit:

[www.austriamicrosystems.com](http://www.austriamicrosystems.com)

***austriamicrosystems*** – a leap ahead